



HOSHIZAKI

Premier KG W80 L DR Glass door refrigerator

PRODUCT SERIES: PREMIER W80
ITEM NUMBER: 184801010
COUNTRY OF ORIGIN: TURKEY



Hoshizaki Premier KG W80 L DR is a 2/1 GN wide glass door refrigerator with a net usable volume of 475 ltr. ranking in energy efficiency class B. It has a cabinet height of 2080-2130 mm and depth of 728 mm without pedal door opener (depth of 800 mm incl. pedal door opener). Legs are adjustable 130-180 mm.

- Ventilated refrigeration system
- Air circulation system
- Automatic fan cut-out when door is opened
- Automatic defrost with re-evaporation of defrost water
- Clean free condenser (condenser filter not needed)
- Heavy duty cabinet
- Climate class 4 cooling system enduring up to +30°C ambient temperature
- Exterior and interior of stainless steel AISI 304
- Anti-tilt shelf supports moulded into the inner lining
- Internal LED lighting
- Right hand hinged reversible door
- Automatic door closing
- Door lock
- Removable magnetic door gaskets
- Pedal door opener with overload protection (included as accessory)
- Pan-shaped inside base with rounded corners to catch fluids
- Low sound level
- IP21 water protection
- Matching design identity as the Premier counters



2/1 GN

ACCESSORIES INCLUDED

4 grey shelves (650 x 530 mm), Pedal door opener with overload protection

OPTIONAL EXTRAS

- Set of legs 130-180 mm
- Set of castors 125 mm (2 x broken and 2 x unbroken)
- Grey shelf with back guard
- Grey bottom shelf with back guard
- Stainless shelf with back guard
- Stainless bottom shelf with back guard
- Set of stainless shelves (3 top and 1 bottom) with back guard
- Master key

WARRANTY PERIOD

**6 Years on Parts & Labour -
based on country agreement**

EXTERIOR

Stainless steel AISI 304

INTERIOR

Stainless steel AISI 304

Refrigerant type: R600a / Refrigerant: 0,08 kg / CO2 equivalent: 0,24 kg

CERTIFICATIONS



Energy consumption	Energy efficiency class	Energy efficiency class standard	Energy Efficiency Index (EEI)
439 kWh/year	B	ISO 22041: 2019	31,62 EEI



HOSHIZAKI

Premier KG W80 L DR

TECHNICAL SPECIFICATIONS

Temperature range	Shelf size	Volume, gross	Net usable volume	Power supply	Connection load	Climate class	Sound level	Ref. capacity (at -10°C)
+2/+12°C	2/1 GN wide	700 l	475 l	230V, 50Hz	120 W	4 (max. ambient temp. of 30 °C with 55% RH)	46 dB(A)	206 W

SHIPPING SPECIFICATIONS

Width (packed)	Depth (packed)	Height (packed)	Volume (packed)	Gross weight	Width	Depth	Height	Height including legs (minimum)	Height including legs (maximum)	Net weight
870 mm	780 mm	2.250 mm	1,527 m ³	140 kg	810 mm	728 mm	1.950 mm	2.080 mm	2.130 mm	130 kg

Disclaimer: Every effort has been made to ensure that the information contained in this spec sheet is accurate at the time of publishing. Hoshizaki Europe BV assumes no responsibility or liability for typographical errors or omissions or for any misinterpretation of the information within the publication and reserves the right to change without notice.

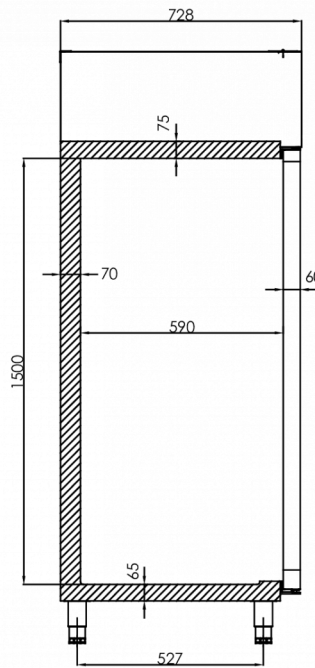
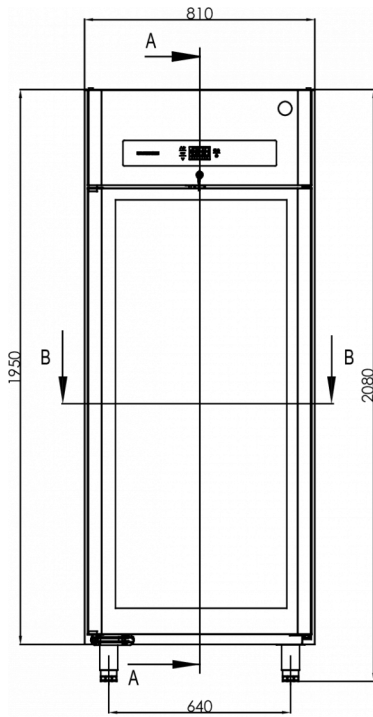

A-A

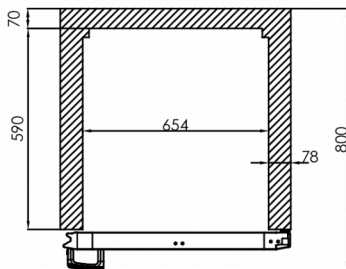

B-B

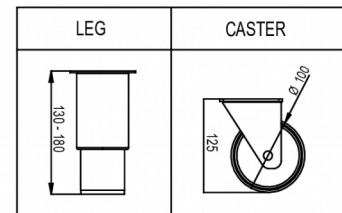

Hoshizaki Belgium
 Hoshizaki Danmark
 Hoshizaki Deutschland
 Hoshizaki France
 Hoshizaki Iberia
 Hoshizaki Italia
 Hoshizaki Middle East

info@hoshizaki.nl
info@hoshizaki.dk
vertrieb@hoshizaki.de
info@hoshizaki.fr
info@hoshizaki.es
commerciale@hoshizaki.it
sales.ex@hoshizaki-europe.com

Hoshizaki Netherlands info@hoshizaki.nl
 Hoshizaki Norge salg@hoshizaki.no
 Hoshizaki Sverige order@hoshizaki.se
 Hoshizaki UK uksales@hoshizaki.uk
 Export countries sales.ex@hoshizaki-europe.com
 Other countries sales.ex@hoshizaki-europe.com

www.hoshizaki-europe.com