



# HOSHIZAKI

## Premier F 2 A DL DR L E 2-Section Freezer Counter

PRODUCT SERIES: PREMIER 270  
ITEM NUMBER: 213000012100  
COUNTRY OF ORIGIN: TURKEY



Hoshizaki Premier F 2 A DL DR L E is a 2-section 1/1 GN freezer counter with 2 doors and a flat worktop. It has a net usable volume of 192 ltr. The shelf width is 325 mm.

- Fan assisted cooling
- Completely front vented
- Unit can be fully integrated. Due to front venting design, no air flow is required to the underneath, sides or back of unit
- Automatic defrost with re-evaporation of defrost water
- Heavy duty cabinet and compressor compartment construction
- Climate class 5 cooling system enduring up to +40°C ambient temperature
- Exterior and interior of stainless steel AISI 304
- A compact slide out refrigeration unit for maintenance and service
- Removable condenser filter for cleaning or replacement
- Compartmentalized cooling unit that is available as one unit
- Reversible doors
- Anti-tilt shelves
- Removable magnetic door gaskets with triple insulation area
- Pan-shaped inside base with rounded corners to catch fluids
- IP 2X water protection
- Matching design identity as the Premier cabinets



**1 / 1 GN**

### ACCESSORIES INCLUDED

2 grey shelves per door section

### OPTIONAL EXTRAS

- Set of legs 125-200 mm
- Set of legs 130-180 mm
- Set of castors 125 mm
- Set of castors 150 mm
- Set of castors 200 mm
- Castor Extension Kit (extends height of castors by 50 mm)
- Stainless shelf, 325 x 530mm
- Grey shelf, 325 x 530mm
- Shelf supports, 2 of
- Door section
- Flat worktop
- Flat worktop with 50mm splashback
- Flat worktop with 100mm splashback

### WARRANTY PERIOD

**6 Years on Parts & Labour -  
based on country agreement**

### EXTERIOR

**Stainless steel AISI 304**

### INTERIOR

**Stainless steel AISI 304**

Refrigerant type: R290 / Refrigerant: 0,055 kg / CO2 equivalent: 0,165 kg

### CERTIFICATIONS



Energy consumption	Energy efficiency class	Energy efficiency class standard	Energy Efficiency Index (EEI)
1.410 kWh/year	C	ISO 22041: 2019	40,26 EEI

Hoshizaki Europe B.V.  
Burgemeester Stramanweg 101  
1101 AA Amsterdam  
The Netherlands

HEBV Amsterdam office T. +31 (0)20 691 8499  
Export line direct T. +31 (0)20 565 0429  
[sales.ex@hoshizaki-europe.com](mailto:sales.ex@hoshizaki-europe.com)  
[service.ex@hoshizaki-europe.com](mailto:service.ex@hoshizaki-europe.com)  
[www.hoshizaki-europe.com](http://www.hoshizaki-europe.com)



# HOSHIZAKI

## Premier F 2 A DL DR L E

### TECHNICAL SPECIFICATIONS

Temperature range	Shelf size	Volume, gross	Net usable volume	Volume, net	Climate class	Sound level
-25/-5°C	1/1 GN	301 l	192 l	192 l	5 (max. ambient 40°C w/ 40% RH)	45 dB(A)
Power supply		Connection load		Ref. capacity (at -30°C)		
230V, 50Hz		425 W		376 W		

### SHIPPING SPECIFICATIONS

Width (packed)	Depth (packed)	Height (packed)	Volume (packed)	Gross weight	Width	Depth	Height	Height including legs (minimum)	Height including legs (maximum)	Net weight
1.340 mm	730 mm	1.081 mm	1,08 m <sup>3</sup>	112 kg	1.314 mm	700 mm	754,2 mm	884,2 mm	1.034,2 mm	100 kg

Disclaimer: Every effort has been made to ensure that the information contained in this spec sheet is accurate at the time of publishing. Hoshizaki Europe BV assumes no responsibility or liability for typographical errors or omissions or for any misinterpretation of the information within the publication and reserves the right to change without notice.

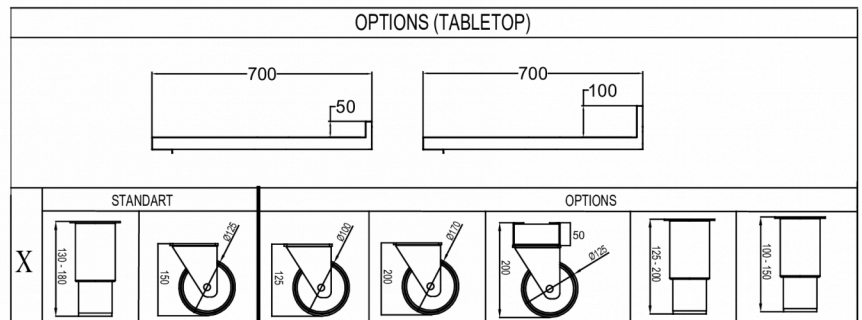
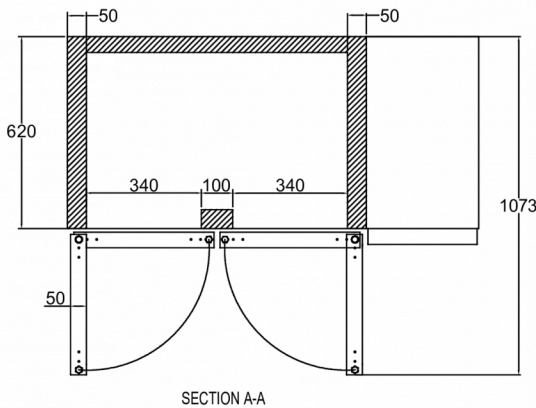
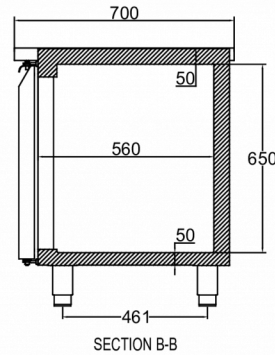
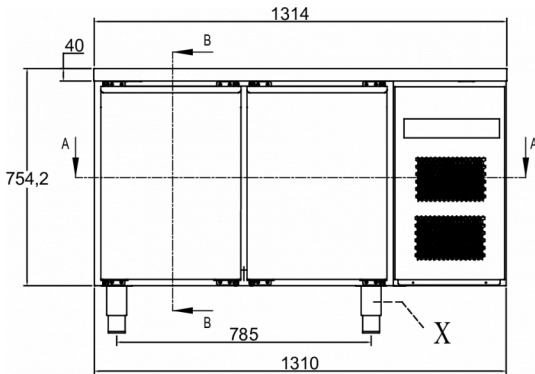

Hoshizaki Belgium  
 Hoshizaki Danmark  
 Hoshizaki Deutschland  
 Hoshizaki France  
 Hoshizaki Iberia  
 Hoshizaki Italia  
 Hoshizaki Middle East

[info@hoshizaki.nl](mailto:info@hoshizaki.nl)  
[info@hoshizaki.dk](mailto:info@hoshizaki.dk)  
[vertrieb@hoshizaki.de](mailto:vertrieb@hoshizaki.de)  
[info@hoshizaki.fr](mailto:info@hoshizaki.fr)  
[info@hoshizaki.es](mailto:info@hoshizaki.es)  
[commerciale@hoshizaki.it](mailto:commerciale@hoshizaki.it)  
[sales.ex@hoshizaki-europe.com](mailto:sales.ex@hoshizaki-europe.com)

Hoshizaki Netherlands [info@hoshizaki.nl](mailto:info@hoshizaki.nl)  
 Hoshizaki Norge [salg@hoshizaki.no](mailto:salg@hoshizaki.no)  
 Hoshizaki Sverige [order@hoshizaki.se](mailto:order@hoshizaki.se)  
 Hoshizaki UK [uksales@hoshizaki.uk](mailto:uksales@hoshizaki.uk)  
 Export countries [sales.ex@hoshizaki-europe.com](mailto:sales.ex@hoshizaki-europe.com)  
 Other countries [sales.ex@hoshizaki-europe.com](mailto:sales.ex@hoshizaki-europe.com)

[www.hoshizaki-europe.com](http://www.hoshizaki-europe.com)