



HOSHIZAKI

HNC-120BE-L-BLH

Sushi display case with LED lighting, left-sided



PRODUCT SERIES: HNC 120
ITEM NUMBER: S051-C174
COUNTRY OF ORIGIN: JAPAN

This Hoshizaki HNC-120BE-L-BLH is a Sushi Case, Left Sided. Our line of refrigerated display cases combines innovative features with a modern and elegant design, and are configured to highlight and preserve the freshness of even the most delicate fish types.

The range is designed to maintain the most natural level of humidity and food-safe temperatures, even during peak serving times with frequent door openings. The Hoshizaki refrigerated showcases assure the most natural level of humidity and food-safe temperature over their entire period of operation of the refrigeration system.

AirflowThe airflow created by the refrigeration effect of the evaporator is smooth and diffused, without forced air-circulation, which would cause dehydration and weight loss, resulting in swift deterioration of the fish or other perishable displayed food.
Temperature ControlOne of the strikingly simple solutions for easy and fast temperature control: The inside tray can be flipped face up or face down to set the perfect inside temperature for different types of fish. The elevated side wings of the trays allow more air circulation, lowering the storage temperature instantly. A thermometer inside the cabinet helps you to monitor the inside temperature at all times.
Attractive DisplayThe tubular-shaped evaporator absorbs the heat continuously. Condensation freezes on its external surface, maintaining an attractive frost layer with no dripping. For extra illumination, the cases can be equipped with optional LED lighting.
ConvenienceThe practical anti-slip top is ideal to place serving trays. The condensing unit of all our models sits either on the right- or left-hand side, with the outflow of air positioned on the sides away from the operator.
Easy CleaningThe sliding door with 150 mm height and the lightweight ABS trays with a wave-shaped profile are easily disassembled and removed for daily cleaning.

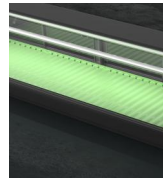
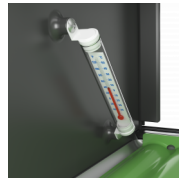

WARRANTY PERIOD
2 Years on Parts & Labour -
based on country agreement

ACCESSORIES INCLUDED

ABS tray (large) x 2, ABS tray (small) x 1

Refrigerant type: R600a / Refrigerant: 0.032 kg

CERTIFICATIONS





HOSHIZAKI

HNC-120BE-L-BLH

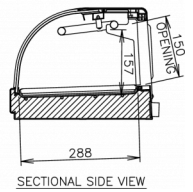
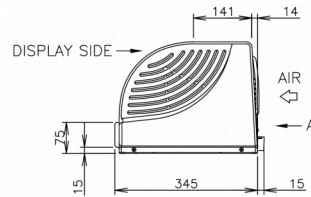
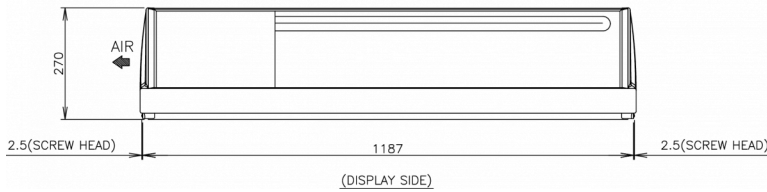
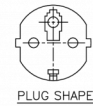
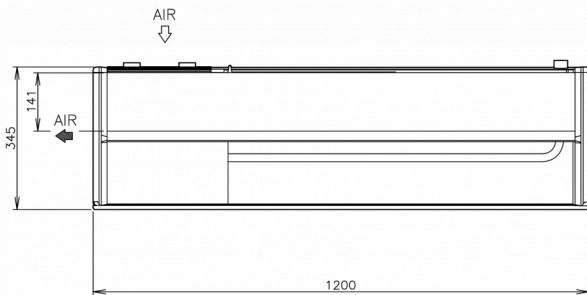
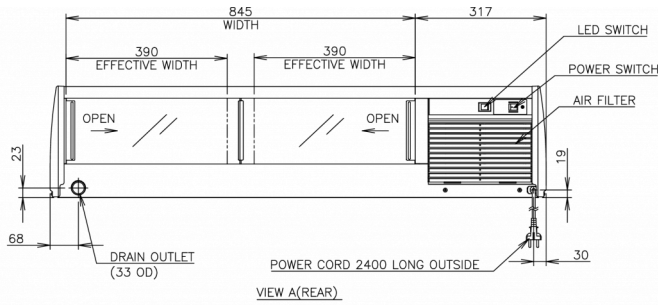

TECHNICAL SPECIFICATIONS

Temperature retention (6h)	Power supply	Connection load	Electric Consumption
5 °C	1/220 - 240V/50Hz	140 W	0.14 kW

Volume, net	LED
42 l	Including LED

SHIPPING SPECIFICATIONS

Gross weight	Width	Depth	Height	Net weight
44 kg	1,200 mm	345 mm	270 mm	32 kg



HOSHIZAKI

Hoshizaki Belgium
 Hoshizaki Danmark
 Hoshizaki Deutschland
 Hoshizaki France
 Hoshizaki Iberia
 Hoshizaki Italia
 Hoshizaki Middle East

info@hoshizaki.nl
info@hoshizaki.dk
vertrieb@hoshizaki.de
info@hoshizaki.fr
info@hoshizaki.es
commerciale@hoshizaki.it
sales.ex@hoshizaki-europe.com

Hoshizaki Netherlands
 Hoshizaki Norge
 Hoshizaki Sverige
 Hoshizaki UK
 Export countries
 Other countries

info@hoshizaki.nl
salg@hoshizaki.no
orderSE@hoshizaki.dk
uksales@hoshizaki.uk
sales.ex@hoshizaki-europe.com
sales.ex@hoshizaki-europe.com

www.hoshizaki-europe.com