



HOSHIZAKI

ADVANCE 50 FTWH70LS4 E 1 door undercounter freezer



PRODUCT SERIES: ADVANCE 50
ITEM NUMBER: WHE81110002
COUNTRY OF ORIGIN: INDIA

Hoshizaki ADVANCE 50 FTWH70LS4 E is an undercounter freezer with right-hand hinged door and integrated handle. It has a net usable volume of 79.7 ltr. Castors H = 125 mm and shelf width is 530 mm.

- Fan-assisted cooling
- Air duct inside for guided airflow
- Air duct at the rear side for guided hot airflow
- Automatic fan cut-out when door is opened
- Automatic defrost with re-evaporation of defrost water
- Electronic controller with temperature indicator
- Climate class 5 cooling system enduring up to +40°C ambient temperature
- Self-closing and reversible door
- Wide opening angle for easy loading of the cabinet
- Door with integrated handle and lock
- Replaceable magnetic door gasket
- Adjustable shelf supports in increments of 25.4 mm/1 inch
- Internal LED light
- Castors height 125 mm
- Pan-shaped inside base with rounded corners to catch fluids
- Ideal for side-by-side positioning

GN Pan capacity:

- GN 1/1 65 mm deep: 5 pc
- GN 1/1 100 mm deep: 4 pc
- GN 1/1 150 mm deep: 3 pc

ACCESSORIES INCLUDED

2 white shelves

OPTIONAL EXTRAS

N/A

WARRANTY PERIOD

**5 Years on Parts & Labour -
based on country agreement**

EXTERIOR

Stainless Steel

INTERIOR

Stainless steel

Refrigerant type: R290 / Refrigerant: 0,055 kg / CO2 equivalent: 0,165 kg

Energy consumption	Energy efficiency class	Energy efficiency class standard	Energy Efficiency Index (EEI)
983 kWh/year	B	ISO 22041: 2019	34,54 EEI

CERTIFICATIONS





HOSHIZAKI

ADVANCE 50 FTWH70LS4 E

TECHNICAL SPECIFICATIONS

Temperature range	GN tray size	Shelf size	Volume, gross	Net usable volume	Climate class	Sound level
-23/-7°C	1/1 GN	W 530 x D 300 mm	169 l	79,7 l	5 (max. ambient 40°C w/ 40% RH)	45,7 dB(A)

Power supply	Connection load	Ref. capacity (at -30°C)
230V, 1N-/50 Hz	220 W	218 W

SHIPPING SPECIFICATIONS

Width (packed)	Depth (packed)	Height (packed)	Volume (packed)	Gross weight	Width	Depth	Height	Net weight
777 mm	856 mm	883 mm	0,587 m3	82 kg	700 mm	785 mm	825 mm	67 kg

Disclaimer: Every effort has been made to ensure that the information contained in this spec sheet is accurate at the time of publishing. Hoshizaki Europe BV assumes no responsibility or liability for typographical errors or omissions or for any misinterpretation of the information within the publication and reserves the right to change without notice.

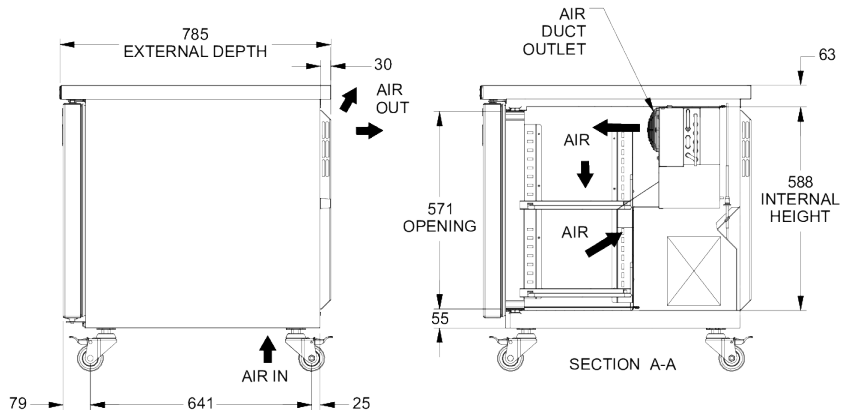
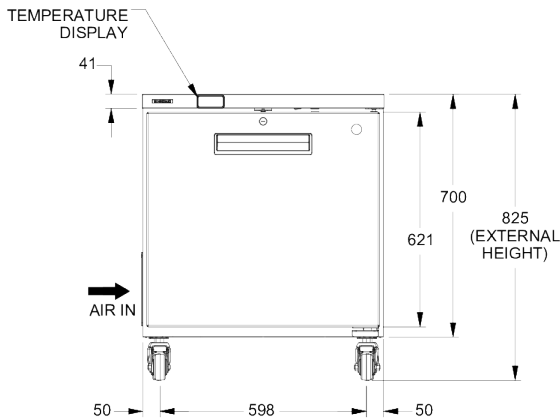
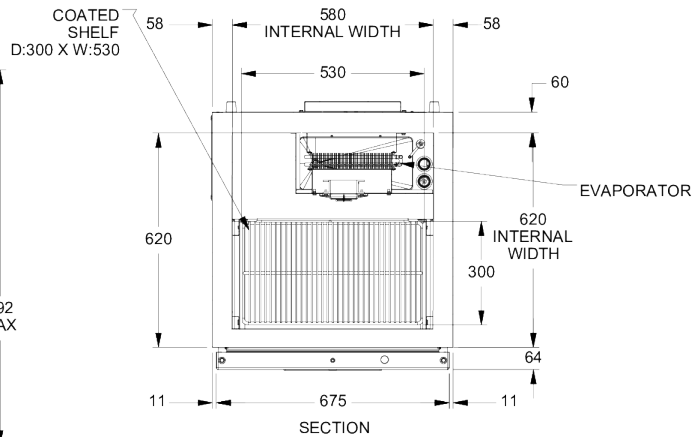
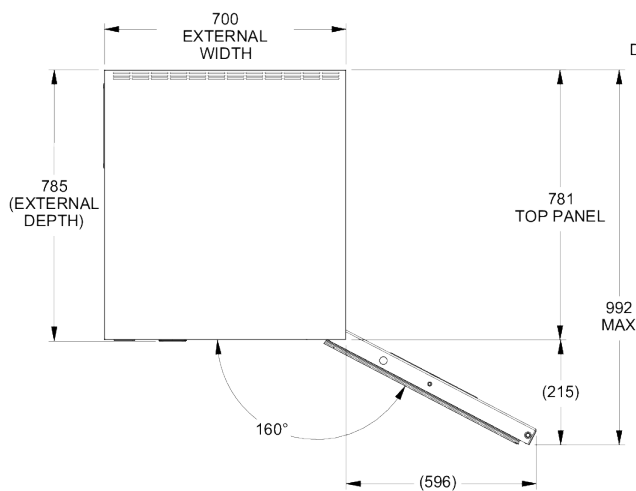

Hoshizaki Belgium
Hoshizaki Danmark
Hoshizaki Deutschland
Hoshizaki France
Hoshizaki Iberia
Hoshizaki Italia
Hoshizaki Middle East

info@hoshizaki.nl
info@hoshizaki.dk
vertrieb@hoshizaki.de
info@hoshizaki.fr
info@hoshizaki.es
commerciale@hoshizaki.it
sales.ex@hoshizaki-europe.com

Hoshizaki Netherlands info@hoshizaki.nl
Hoshizaki Norge salg@hoshizaki.no
Hoshizaki Sverige order@hoshizaki.se
Hoshizaki UK uksales@hoshizaki.uk
Export countries sales.ex@hoshizaki-europe.com
Other countries sales.ex@hoshizaki-europe.com

www.hoshizaki-europe.com