



HOSHIZAKI

FM-1800ALKE-R452N-SB

Nugget Ice Maker, Modular

Production Capacity (kg/24h) - AT 10°C, WT 10°C:
1,590



ICE TYPE: Nugget



ACCESSORIES INCLUDED

Installation kit

OPTIONAL EXTRAS

4HC-H water filtration

CORRESPONDING WATER FILTERS

4HC-H Triple Water Filter, 4HC Replacement Cartridge

CORRESPONDING BIN(S)

B-340SB

CORRESPONDING TOP KITS

TK-48 for B-340SB (optional, not required), TK-FM1800 for B-340SB

PRODUCT SERIES: FLAKE & NUGGET ICEMAKERS

ITEM NUMBER: F074-C207

COUNTRY OF ORIGIN: UK

Hoshizaki FM-1800ALKE-R452N is a modular ice maker producing up to 1590 kg of nugget ice per 24 hours. It is compatible with our storage bins.

This model is without compressor or condenser and is for remote connection.

- FM models can be converted to either flake or nugget ice only by a qualified engineer
- CleanCycle6 system for rinse of built up impurities (minerals) every 6 hours
- Water consumption is equal to the ice production
- Ice making system with an automatic rinse cycle
- Closed water circuit for contamination protection
- Electronic controller
- Operation time-based parts replacement system for preventive maintenance
- Auger is made of double hardened stainless steel
- Carbon graphite bushings allows the machine to work without grease
- Cleanable air filter

WARRANTY PERIOD

2 Years on Parts & Labour

EXTERIOR

Stainless steel AISI 441, Galvanized steel (Rear)

Refrigerant compatibility: R452A

OPERATING CONDITIONS

Ambient temperature (minimum): 5 °C, Ambient temperature (maximum): 40 °C, Water supply pressure (minimum): 0.05MPa (0.5bar), Water supply pressure (maximum): 0.8MPa (8bar), Water supply temperature (minimum): 5 °C, Water supply temperature (maximum): 35 °C, Voltage range (Rated Voltage): ±10%

CERTIFICATIONS





HOSHIZAKI

FM-1800ALKE-R452N-SB

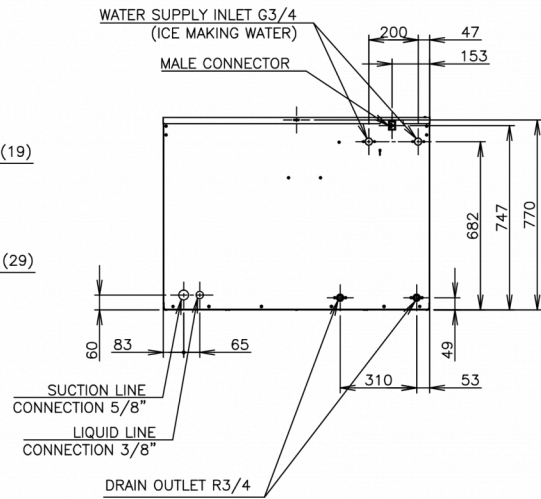
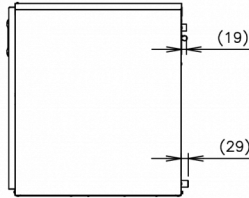
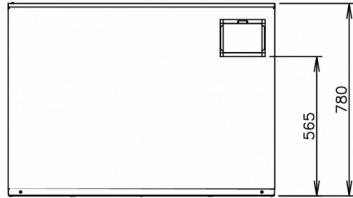
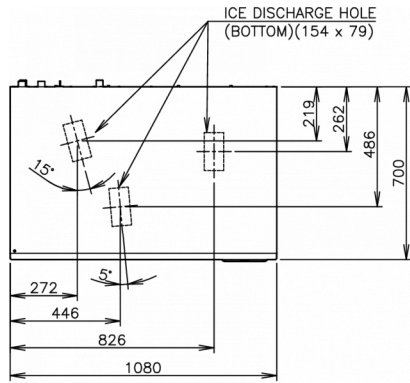

TECHNICAL SPECIFICATIONS

Cooling system	Power supply	Production Capacity (kg/24h) - AT 10°C, WT 10°C	Production Capacity (kg/24h) - AT 21°C, WT 15°C	Production Capacity (kg/24h) - AT 32°C, WT 21°C	Water consumption (m3/24h) - AT 10°C, WT 10°C
Remote Condenser	1/220 - 240V/50Hz	1,590	1,380	1,200	1.6

SHIPPING SPECIFICATIONS

Width (packed)	Depth (packed)	Height (packed)	Volume (packed)	Gross weight	Width	Depth	Height	Net weight
1,191 mm	820 mm	947 mm	0.925 m3	155 kg	1,080 mm	700 mm	780 mm	140 kg

Disclaimer: Every effort has been made to ensure that the information contained in this spec sheet is accurate at the time of publishing. Hoshizaki Europe BV assumes no responsibility or liability for typographical errors or omissions or for any misinterpretation of the information within the publication and reserves the right to change without notice.

Please observe: This type of icemaker is on special order only. Please take longer lead times into consideration.



HOSHIZAKI

Hoshizaki Middle East

sales.ex@hoshizaki-europe.com

www.hoshizaki-europe.com