



HOSHIZAKI

FM-480AWKE-R452-SB

Flaker, Modular

Production Capacity (kg/24h) - AT 10°C, WT 10°C: 420



ICE TYPE: Flake



ACCESSORIES INCLUDED

Installation kit, Mounting bracket

OPTIONAL EXTRAS

4HC-H water filtration

CORRESPONDING WATER FILTERS

4HC-H Twin Water Filter, 4HC Replacement Cartridge

CORRESPONDING BIN(S)

B-140SB, B-210SB, B-340SB

CORRESPONDING TOP KITS

TK-30 for B-140SA, B-210SA, B340SA (optional, not required), TK-8D for B-210SA, TK-8D + TK18D for B-340SA

PRODUCT SERIES: FM, FM 480

ITEM NUMBER: F082-C222

COUNTRY OF ORIGIN: UK

Hoshizaki FM-480AWKE-R452 is modular, water cooled ice maker producing up to 420 kg of flake ice per 24 hours. This model is compatible with our storage bins.

Hoshizaki recommends that the water-cooled condenser should be connected to a closed circuit recirculating type cooling system utilizing a tower, water chiller or similar. Water make up should be via a ball valve/break tank arrangement. Whilst connecting a water-cooled condenser to a mains water (potable) supply will not affect the performance of the machine, it will most certainly cause high water use and waste of a valuable resource that is not recommended. It is likely that the connection of such units to the mains water supply may be a contravention of local water authority by-laws.

- FM models can be converted to either flake or nugget ice only by a qualified engineer
- CleanCycle6 system for rinse of built up impurities (minerals) every 6 hours
- Water consumption is equal to the ice production
- Ice making system with an automatic rinse cycle
- Closed water circuit for contamination protection
- Electronic controller
- Operation time-based parts replacement system for preventive maintenance
- Auger is made of double hardened stainless steel
- Carbon graphite bushings allows the machine to work without grease

WARRANTY PERIOD

2 Years on Parts & Labour

EXTERIOR

Stainless steel AISI 441, Galvanized steel (Rear)

Refrigerant type: R452 / Refrigerant: 0.37 kg / CO2 equivalent: 791.8 kg

OPERATING CONDITIONS

Ambient temperature (minimum): 5 °C, Ambient temperature (maximum): 40 °C, Water supply pressure (minimum): 0.05MPa (0.5bar), Water supply pressure (maximum): 0.8MPa (8bar), Water supply temperature (minimum): 5 °C, Water supply temperature (maximum): 35 °C, Voltage range: Rated Voltage ±6%

CERTIFICATIONS





HOSHIZAKI

FM-480AWKE-R452-SB

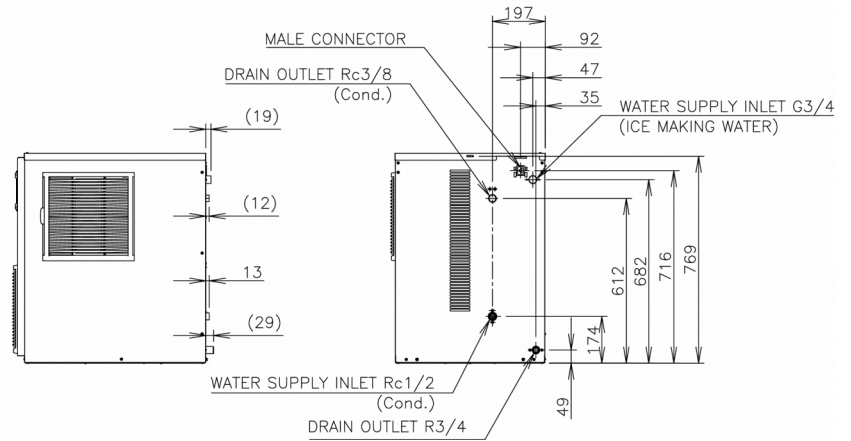
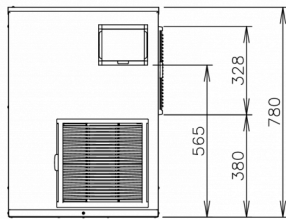
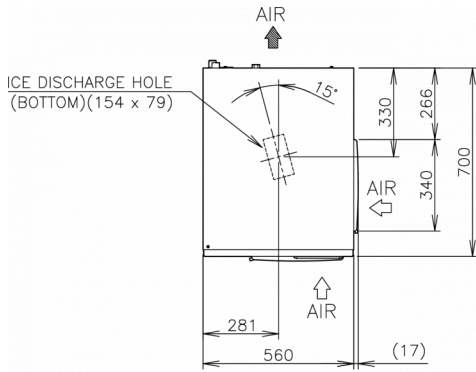

TECHNICAL SPECIFICATIONS

Cooling system	Power supply	Energy consumption	Cooling water at 21°C / max flow rate L/min	Heat Rejection (AT 32°C, WT 21°C)	Production Capacity (kg/24h) - AT 10°C, WT 10°C	Production Capacity (kg/24h) - AT 21°C, WT 15°C	Production Capacity (kg/24h) - AT 32°C, WT 21°C
Water Cooled	1/220 - 240V/50Hz	1.385 kWh	1	2.69 kW	420	380	340

SHIPPING SPECIFICATIONS

Width (packed)	Depth (packed)	Height (packed)	Volume, gross	Gross weight	Width	Depth	Height	Net weight
665 mm	820 mm	950 mm	0.518 l	102 kg	560 mm	700 mm	780 mm	95 kg

Disclaimer: Every effort has been made to ensure that the information contained in this spec sheet is accurate at the time of publishing. Hoshizaki Europe BV assumes no responsibility or liability for typographical errors or omissions or for any misinterpretation of the information within the publication and reserves the right to change without notice.

Please observe: This type of icemaker is on special order only. Please take longer lead times into consideration.



HOSHIZAKI

Hoshizaki Middle East

sales.ex@hoshizaki-europe.com

www.hoshizaki-europe.com