



HOSHIZAKI

FM-120KE-50-HCN

Nugget Ice Maker, Self Contained

Production Capacity (kg/24h) - AT 10°C, WT 10°C: 110

Storage bin capacity: 65 kg



ICE TYPE: Nugget



ACCESSORIES INCLUDED

Installation kit, Scoop

OPTIONAL EXTRAS

4HC-H water filtration

CORRESPONDING WATER FILTERS

4HC-H Single Water Filter, 4HC Replacement Cartridge

PRODUCT SERIES: FLAKE & NUGGET ICEMAKERS

ITEM NUMBER: F115-C129

COUNTRY OF ORIGIN: UK

Hoshizaki FM-120KE-50-HCN is a self-contained ice maker producing up to 110 kg of nugget ice per 24 hours.

- FM models can be converted to either flake or nugget ice only by a qualified engineer
- CleanCycle6 system for rinse of built up impurities (minerals) every 6 hours
- Water consumption is equal to the ice production
- Ice making system with an automatic rinse cycle
- Closed water circuit for contamination protection
- Electronic controller
- Operation time-based parts replacement system for preventive maintenance
- Auger is made of double hardened stainless steel
- Carbon graphite bushings allows the machine to work without grease
- Cleanable air filter
- Removable door gasket

WARRANTY PERIOD

2 Years on Parts & Labour

EXTERIOR

Stainless steel AISI 441, Galvanized steel (Rear)

Refrigerant type: R290 / Refrigerant: 0.1 kg / CO2 equivalent: 0.3 kg

OPERATING CONDITIONS

Ambient temperature (minimum): 5 °C, Ambient temperature (maximum): 40 °C, Water supply pressure (minimum): 0.05MPa (0.5bar), Water supply pressure (maximum): 0.8MPa (8bar), Water supply temperature (minimum): 5 °C, Water supply temperature (maximum): 35 °C, Voltage range (Rated Voltage): ±6%

CERTIFICATIONS





HOSHIZAKI

FM-120KE-50-HCN

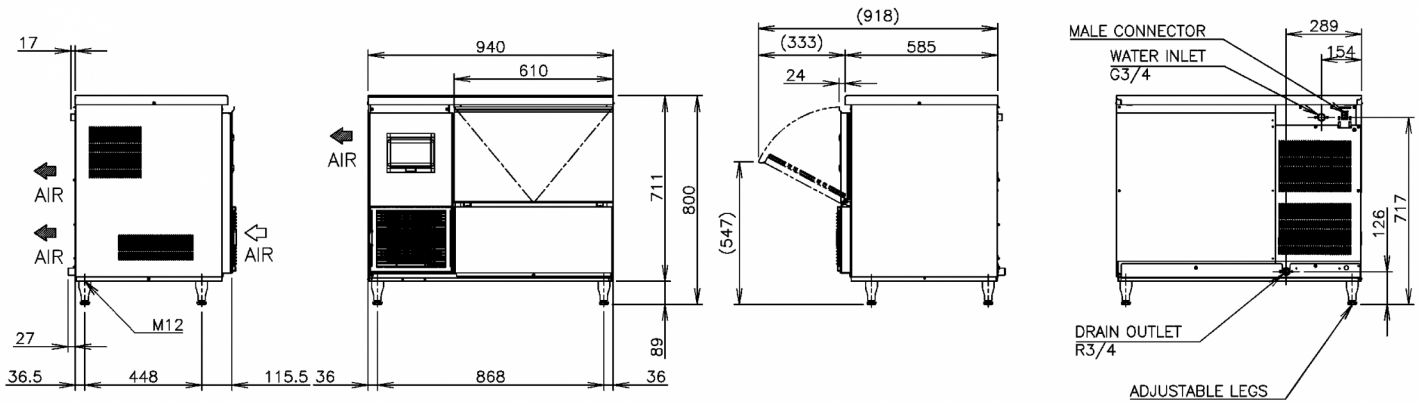
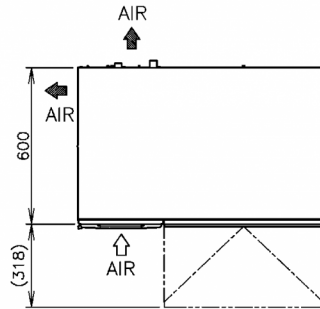

TECHNICAL SPECIFICATIONS

Cooling system	Power supply	Electric Consumption	Electrical circuit breaker protection	Heat Rejection (AT 32°C, WT 21°C)	Production Capacity (kg/24h) - AT 10°C, WT 10°C	Production Capacity (kg/24h) - AT 21°C, WT 15°C	Production Capacity (kg/24h) - AT 32°C, WT 21°C	Water consumption (m ³ /24h) - AT 10°C, WT 10°C
Air Cooled	1/220 - 240V/50Hz	0.355 kW	6 A	0.655 kW	110	96	75	0.11

SHIPPING SPECIFICATIONS

Width (packed)	Depth (packed)	Height (packed)	Volume (packed)	Volume, gross	Gross weight	Width	Depth	Height	Dimensions legs	Net weight
1,046 mm	706 mm	887 mm	0.655 m ³	0.655 l	88 kg	940 mm	600 mm	800 mm	Including legs at 89 mm	76 kg

Disclaimer: Every effort has been made to ensure that the information contained in this spec sheet is accurate at the time of publishing. Hoshizaki Europe BV assumes no responsibility or liability for typographical errors or omissions or for any misinterpretation of the information within the publication and reserves the right to change without notice.

Hoshizaki Middle East

sales.ex@hoshizaki-europe.com



HOSHIZAKI

www.hoshizaki-europe.com