



HOSHIZAKI

KMD-270ABE-R452

Crescent Ice Maker, Modular

Production Capacity (kg/24h) - AT 10°C, WT 10°C: 275



ICE TYPE: Crescent Edge



PRODUCT SERIES: CRESCENT ICEMAKERS

ITEM NUMBER: M098

COUNTRY OF ORIGIN: UK

Hoshizaki KMD-270ABE-R452 is a modular ice maker producing up to 275 kg of crescent EDGE ice per 24 hours. This model is compatible with our storage bins.

Crescent EDGE ice dimensions and weight - disclaimer: The drawing is for illustration purposes only. Size and weight may differ due to local installation conditions.

- CycleSaver® technology with doublesided stainless steel evaporator which produces ice on both sides
- Stainless steel evaporator allow the use of mineral removal deposit removal chemical. No 'flaking' of the evaporator
- EverCheck™ Control Board with audible alarm and diagnostic feature
- Ice making system with an automatic rinse cycle
- Fresh water every 10, 5, 2 or 1 cycle (10 is factory standard)
- Closed water circuit for contamination protection
- Electronic controller
- Cleanable air filter
- Compatible with standard 22" drink/ice dispenser systems

WARRANTY PERIOD

2 Years on Parts & Labour

EXTERIOR

Stainless steel AISI 441, Galvanized steel (Rear), Plastic (Louver)

Refrigerant type: R452A / Refrigerant: 0.78 kg / CO2 equivalent: 1,669 kg

OPERATING CONDITIONS

Ambient temperature (minimum): 7 °C, Ambient temperature (maximum): 40 °C, Water supply pressure (minimum): 0.07MPa (0.7bar), Water supply pressure (maximum): 0.8MPa (8bar), Water supply temperature (minimum): 7 °C, Water supply temperature (maximum): 35 °C, Voltage range (Rated Voltage): ±6%

OPTIONAL EXTRAS

4HC-H water filtration

CORRESPONDING WATER FILTERS

4HC-H Twin Water Filter, 4HC Replacement Cartridge

CORRESPONDING BIN(S)

B-140SB, B-210SB, B-340SB

CORRESPONDING TOP KITS

TK-8D for B-210SB, TK-8D + TK18D for B-340SB

CERTIFICATIONS





HOSHIZAKI

KMD-270ABE-R452

POWER CORD
2000 LONG OUTSIDE

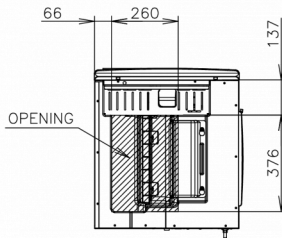
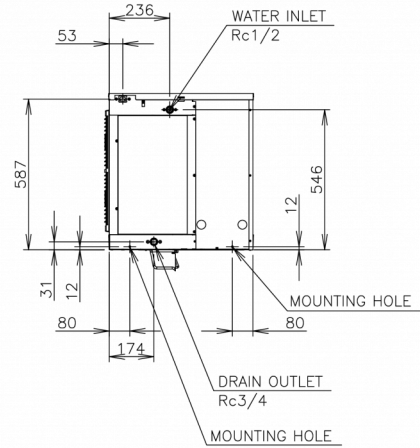
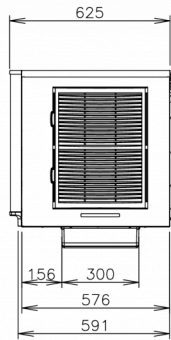
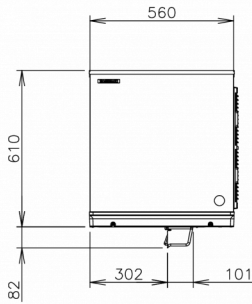
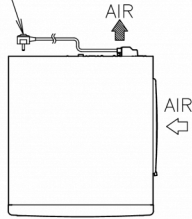

TECHNICAL SPECIFICATIONS

Cooling system	Power supply	Electric Consumption	Electrical circuit breaker protection	Heat Rejection (AT 32°C, WT 21°C)	Production Capacity (kg/24h) - AT 10°C, WT 10°C	Production Capacity (kg/24h) - AT 21°C, WT 15°C	Production Capacity (kg/24h) - AT 32°C, WT 21°C	Water consumption (m3/24h) - AT 10°C, WT 10°C
Air Cooled	1/220 - 240V/50Hz	0.984 kW	5 A	2.435 kW	275	255	221	0.98

SHIPPING SPECIFICATIONS

Width (packed)	Depth (packed)	Height (packed)	Volume (packed)	Gross weight	Width	Depth	Height	Net weight
710 mm	659 mm	796 mm	0.372 m3	66 kg	560 mm	625 mm	610 mm	57 kg

Disclaimer: Every effort has been made to ensure that the information contained in this spec sheet is accurate at the time of publishing. Hoshizaki Europe BV assumes no responsibility or liability for typographical errors or omissions or for any misinterpretation of the information within the publication and reserves the right to change without notice.

Hoshizaki Middle East

sales.ex@hoshizaki-europe.com



HOSHIZAKI

www.hoshizaki-europe.com