



HOSHIZAKI

IM-45CPE-E

Cuber, Self Contained

Production Capacity (kg/24h) - AT 10°C, WT 10°C: 47

Storage bin capacity: 15 kg



ICE TYPE: Large cubes, Standard



Cube Size: **L-STANDARD**
Weight: 23 g

ACCESSORIES INCLUDED

Installation kit, Legs, Scoop

OPTIONAL EXTRAS

4HC-H water filtration

CORRESPONDING WATER FILTERS

4HC-H Single Water Filter, 4HC Replacement Cartridge

PRODUCT SERIES: CUBE ICEMAKERS

ITEM NUMBER: M112-D300

COUNTRY OF ORIGIN: UK

Hoshizaki IM-45CPE-E EliteCube model is a self-contained ice maker with internal drain pump and UVC sanitization function producing up to 47 kg of cube ice per 24 hours.

Ice cube dimensions and weight - disclaimer: The drawing is for illustration purposes only. Cube size and weight may differ due to local installation conditions.

- Ice making system with an automatic rinse cycle
- Each ice cycle is made with fresh water
- Closed Cell System helps produce compact, hard and geometrically perfect ice
- Closed water circuit for contamination protection
- Easy external access to control panel
- UV sanitization function sanitizing air and water (UV-C irradiation)
- Internal drain pump
- System comes with a magnetic DC water pump with variable speed that has no direct coupling, which prevents any leakage
- Cleanable air filter
- Removable door gasket
- Easily removable water pan assembly

WARRANTY PERIOD

3 Years on Parts & Labour

EXTERIOR

Stainless steel AISI 441, Galvanized steel (Rear)

Refrigerant type: R290 / Refrigerant: 0.07 kg / CO2 equivalent: 0.21 kg

OPERATING CONDITIONS

Ambient temperature (minimum): 1 °C, Ambient temperature (maximum): 40 °C, Water supply pressure (minimum): 0.07MPa (0.7bar), Water supply pressure (maximum): 0.8MPa (8bar), Water supply temperature (minimum): 5 °C, Water supply temperature (maximum): 35 °C, Voltage range (Rated Voltage): ±6%

CERTIFICATIONS





HOSHIZAKI

IM-45CPE-E

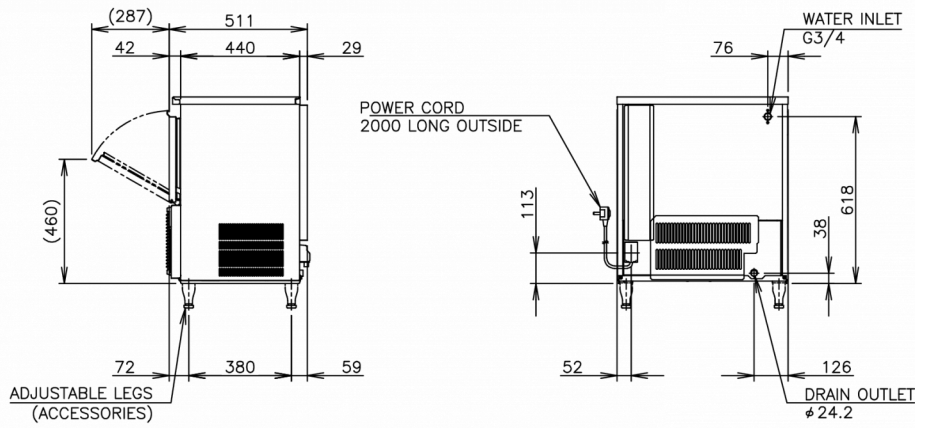
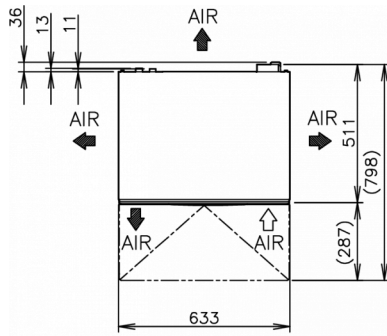

TECHNICAL SPECIFICATIONS

Cooling system	Power supply	Electrical circuit breaker protection	Heat Rejection (AT 32°C, WT 21°C)	Production Capacity (kg/24h) - AT 10°C, WT 10°C	Production Capacity (kg/24h) - AT 21°C, WT 15°C	Production Capacity (kg/24h) - AT 32°C, WT 21°C	Water consumption (m ³ /24h) - AT 10°C, WT 10°C
Air Cooled	1/220 - 240V/50Hz	5 A	0.71 kW	47	39	31	0.11

SHIPPING SPECIFICATIONS

Width (packed)	Depth (packed)	Height (packed)	Volume (packed)	Gross weight	Width	Depth	Height	Dimensions legs	Net weight
735 mm	570 mm	864 mm	0.362 m ³	54 kg	633 mm	511 mm	690 mm	for legs add 90-125 mm	44 kg

Disclaimer: Every effort has been made to ensure that the information contained in this spec sheet is accurate at the time of publishing. Hoshizaki Europe BV assumes no responsibility or liability for typographical errors or omissions or for any misinterpretation of the information within the publication and reserves the right to change without notice.

Hoshizaki Middle East

sales.ex@hoshizaki-europe.com



HOSHIZAKI

www.hoshizaki-europe.com