



HOSHIZAKI

IM-65WPE-E

Cuber, Self Contained

Production Capacity (kg/24h) - AT 10°C, WT 10°C: 62

Storage bin capacity: 26 kg



ICE TYPE: Large cubes, Standard



Cube Size: **L-STANDARD**
Weight: 23 g

ACCESSORIES INCLUDED

Ice chute, Installation kit, Scoop

OPTIONAL EXTRAS

4HC-H water filtration

CORRESPONDING WATER FILTERS

4HC-H Single Water Filter, 4HC Replacement Cartridge

PRODUCT SERIES: CUBE ICEMAKERS

ITEM NUMBER: M113-D313

COUNTRY OF ORIGIN: UK

Hoshizaki IM-65WPE-E EliteCube model is a self-contained water cooled ice maker with internal drain pump and UV-C sanitization function producing up to 62 kg of cube ice per 24 hours.

Hoshizaki recommends that the water-cooled condenser should be connected to a closed circuit recirculating type cooling system utilizing a tower, water chiller or similar. Water make up should be via a ball valve/break tank arrangement. Whilst connecting a water-cooled condenser to a mains water (potable) supply will not affect the performance of the machine, it will most certainly cause high water use and waste of a valuable resource that is not recommended. It is likely that the connection of such units to the mains water supply may be a contravention of local water authority by-laws.

Ice cube dimensions and weight - disclaimer: The drawing is for illustration purposes only. Cube size and weight may be differ due to local installation conditions.

- Ice making system with an automatic rinse cycle
- Each ice cycle is made with fresh water
- Closed Cell System helps produce compact, hard and geometrically perfect ice
- Closed water circuit for contamination protection
- Easy external access to control panel
- Internal drain pump
- UV sanitization function sanitizing air and water (UV-C irradiation)
- System comes with a magnetic DC water pump with variable speed and that has no direct coupling, which prevents any leakage
- Removable door gasket
- Easily removable water pan assembly

WARRANTY PERIOD

3 Years on Parts & Labour

EXTERIOR

Stainless steel AISI 441, Galvanized steel (Rear)

Refrigerant type: R290 / Refrigerant: 0.11 kg / CO2 equivalent: 0.33 kg

OPERATING CONDITIONS

Ambient temperature (minimum): 1 °C, Ambient temperature (maximum): 40 °C, Water supply pressure (minimum): 0.07MPa (0.7bar), Water supply pressure (maximum): 0.8MPa (8bar), Water supply temperature (minimum): 5 °C, Water supply temperature (maximum): 35 °C, Voltage range (Rated Voltage): ±6%

CERTIFICATIONS





HOSHIZAKI

IM-65WPE-E

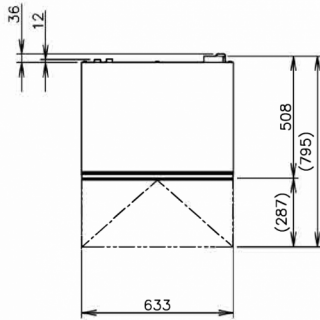

TECHNICAL SPECIFICATIONS

Cooling system	Power supply	Electric Consumption	Electrical circuit breaker protection	Heat Rejection (AT 32°C, WT 21°C)	Production Capacity (kg/24h) - AT 10°C, WT 10°C	Production Capacity (kg/24h) - AT 21°C, WT 15°C	Production Capacity (kg/24h) - AT 32°C, WT 21°C
Water Cooled	1/220 - 240V/50Hz	0.28 kW	5 A	0.43 kW	62	60	56

SHIPPING SPECIFICATIONS

Width (packed)	Depth (packed)	Height (packed)	Volume (packed)	Gross weight	Width	Depth	Height	Dimensions legs	Net weight
735 mm	570 mm	1,012 mm	0.424 m ³	58 kg	633 mm	506 mm	840 mm	for legs add 90-125 mm	48 kg

Disclaimer: Every effort has been made to ensure that the information contained in this spec sheet is accurate at the time of publishing. Hoshizaki Europe BV assumes no responsibility or liability for typographical errors or omissions or for any misinterpretation of the information within the publication and reserves the right to change without notice.

Hoshizaki Middle East

sales.ex@hoshizaki-europe.com



HOSHIZAKI

www.hoshizaki-europe.com