



HOSHIZAKI

Premier F 3 A DL DL DR C U 3-Section Freezer Counter

PRODUCT SERIES: PREMIER 370
ITEM NUMBER: 313000112210
COUNTRY OF ORIGIN: TURKEY



Hoshizaki Premier F 3 A DL DL DR C U is a 3-section 1/1 GN freezer counter with 3 doors and a flat worktop. It has a net usable volume of 288 ltr. Castors H = 150mm and shelf width is 325mm.

- Fan assisted cooling
- Completely front vented
- Unit can be fully integrated. Due to front venting design, no air flow is required to the underneath, sides or back of unit
- Automatic defrost with re-evaporation of defrost water
- Heavy duty cabinet and compressor compartment construction
- Climate class 5 cooling system enduring up to +40°C ambient temperature
- Exterior and interior of stainless steel AISI 304
- A compact slide out refrigeration unit for maintenance and service
- Removable condenser filter for cleaning or replacement
- Compartmentalized cooling unit that is available as one unit
- Reversible doors
- Anti-tilt shelves
- Removable magnetic door gaskets with triple insulation area
- Pan-shaped inside base with rounded corners to catch fluids
- IP 2X water protection
- Matching design identity as the Premier cabinets



1 / 1 GN

ACCESSORIES INCLUDED

2 grey shelves per door section

OPTIONAL EXTRAS

- Set of legs 125-200mm
- Set of legs 130-180mm
- Set of castors 125mm
- Set of castors 150mm
- Set of castors 200mm
- Mini Castors - 2 braked and 2 unbraked 88mm
- Stainless shelf, 325 x 530mm
- Grey shelf, 325 x 530mm
- Shelf supports, 2 of
- Door section
- Flat worktop
- Flat worktop with 50mm splashback
- Flat worktop with 100mm splashback

WARRANTY PERIOD
6 Years on Parts & Labour

EXTERIOR
Stainless steel AISI 304

INTERIOR
Stainless steel AISI 304

Refrigerant type: R290 / Refrigerant: 0.055 kg / CO2 equivalent: 0.165 kg

CERTIFICATIONS



Energy consumption	Energy efficiency class	Energy efficiency class standard	Energy Efficiency Index (EEI)
1,949 kWh/year	C	ISO 22041: 2019	47.98 EEI



HOSHIZAKI

Premier F 3 A DL DL DR C U

TECHNICAL SPECIFICATIONS

Temperature range	Shelf size	Volume, gross	Net usable volume	Volume, net	Climate class	Sound level
-25/-5°C	1/1 GN	463 l	288 l	288 l	5 (max. ambient 40°C w/ 40% RH)	45 dB(A)

Power supply	Connection load	Ref. capacity (at -30°C)
230V, 50Hz	425 W	376 W

SHIPPING SPECIFICATIONS

Width (packed)	Depth (packed)	Height (packed)	Volume (packed)	Gross weight	Width	Depth	Height	Net weight
1,783 mm	730 mm	1,103 mm	1.56 m3	146 kg	1,755 mm	700 mm	904.2 mm	133 kg

Disclaimer: Every effort has been made to ensure that the information contained in this spec sheet is accurate at the time of publishing. Hoshizaki Europe BV assumes no responsibility or liability for typographical errors or omissions or for any misinterpretation of the information within the publication and reserves the right to change without notice.

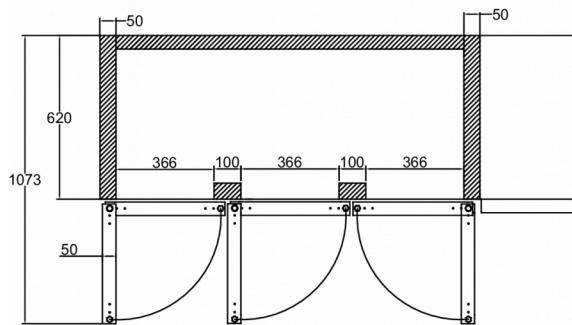
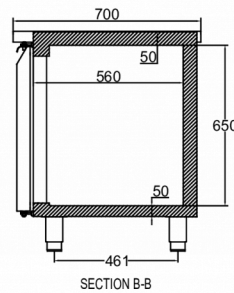
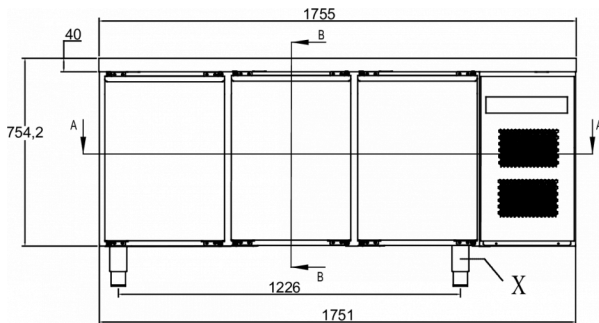

SECTION A-A

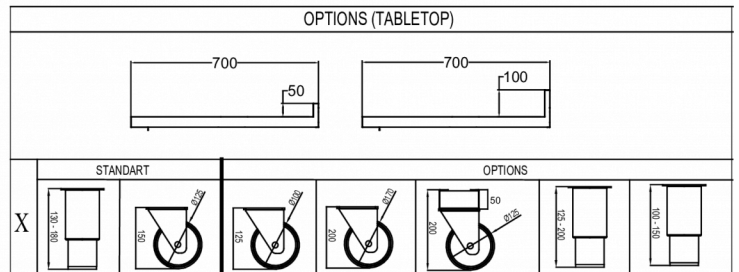

Hoshizaki Belgium
 Hoshizaki Danmark
 Hoshizaki Deutschland
 Hoshizaki France
 Hoshizaki Iberia
 Hoshizaki Italia
 Hoshizaki Middle East

info@hoshizaki.nl
info@hoshizaki.dk
vertrieb@hoshizaki.de
info@hoshizaki.fr
info@hoshizaki.es
commerciale@hoshizaki.it
sales.ex@hoshizaki-europe.com

Hoshizaki Netherlands info@hoshizaki.nl
 Hoshizaki Norge salg@hoshizaki.no
 Hoshizaki Sverige orderSE@hoshizaki.dk
 Hoshizaki UK uksales@hoshizaki.uk
 Export countries sales.ex@hoshizaki-europe.com
 Other countries sales.ex@hoshizaki-europe.com

www.hoshizaki.uk