



HOSHIZAKI

ADVANCE ACF-180DG-LRR-RRS-C1 U

3-Section Freezer Counter with 100mm splashback



PRODUCT SERIES: ADVANCE 180
ITEM NUMBER: 899020865
COUNTRY OF ORIGIN: TURKEY

Hoshizaki Advance ACF-180DG-LRR-RRS-C1 U is a 3-section 1/1 GN freezer counter with three doors and a flat worktop with 100mm splashback. It has a net usable volume of 257 ltr. The height excluding castors is 800mm. The total height including castors and 100mm splashback is 950mm. Castors = H 150mm (C1). Shelf width is 325mm.

- Fan assisted cooling
- Automatic defrost with re-evaporation of defrost water
- Heavy duty cabinet and compressor compartment construction
- Climate class 5 cooling system enduring up to +40°C ambient temperature
- Exterior and interior of stainless steel
- Compartmentalized cooling unit that is available as one unit
- A compact slide out refrigeration unit for maintenance and service
- Removable condenser filter for cleaning or replacement
- Reversible doors
- Anti-tilt shelves
- Removable magnetic door gaskets with triple insulation area
- Pan-shaped inside base with rounded corners to catch fluids
- IP 21 water protection
- Matching design identity as the Advance cabinets



1 / 1 GN

ACCESSORIES INCLUDED

2 grey shelves per door section

OPTIONAL EXTRAS

- Set of legs 130-180mm (L1)
- Set of legs 135-200mm (L2)
- Set of 4 Castors for 900mm Counter-top (C2)
- Castor Extension Kit (extends height of castors by 50mm)
- Flat worktop
- Shelf support - Left
- Shelf support - Right
- Stainless shelf
- Grey shelf

WARRANTY PERIOD
5 Years on Parts & Labour

EXTERIOR
Stainless Steel

INTERIOR
Stainless steel

Refrigerant type: R290 / Refrigerant: 0.06 kg / CO2 equivalent: 0.18 kg

CERTIFICATIONS



| Energy consumption | Energy efficiency class | Energy efficiency class standard | Energy Efficiency Index (EEI) |
|--------------------|-------------------------|----------------------------------|-------------------------------|
| 2,892 kWh/year | D | ISO 22041: 2019 | 74.53 EEI |



HOSHIZAKI

ADVANCE ACF-180DG-LRR-RRS-C1 U

TECHNICAL SPECIFICATIONS

| Temperature range | Shelf size | Volume, gross | Net usable volume | Power supply | Connection load | Climate class | Ref. capacity (at -30°C) |
|-------------------|------------|---------------|-------------------|--------------|-----------------|---------------------------------|--------------------------|
| -22/-5°C | 1/1 GN | 457 l | 257 l | 230V, 50Hz | 639 W | 5 (max. ambient 40°C w/ 40% RH) | 506 W |

SHIPPING SPECIFICATIONS

| Width (packed) | Depth (packed) | Height (packed) | Volume (packed) | Gross weight | Width | Depth | Height | Net weight |
|----------------|----------------|-----------------|---------------------|--------------|----------|--------|--------|------------|
| 1,870 mm | 820 mm | 1,050 mm | 1.61 m ³ | 142 kg | 1,780 mm | 700 mm | 950 mm | 130 kg |

Disclaimer: Every effort has been made to ensure that the information contained in this spec sheet is accurate at the time of publishing. Hoshizaki Europe BV assumes no responsibility or liability for typographical errors or omissions or for any misinterpretation of the information within the publication and reserves the right to change without notice.

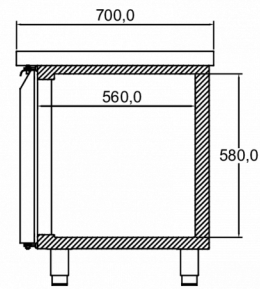
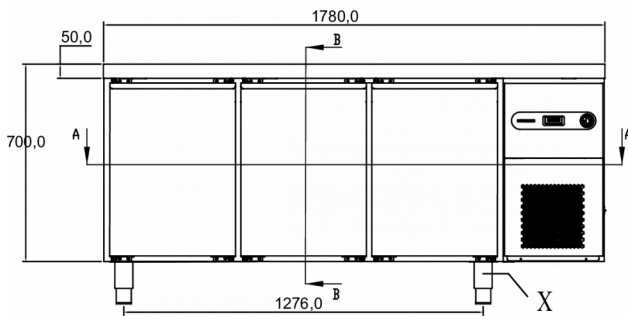

SECTION B-B

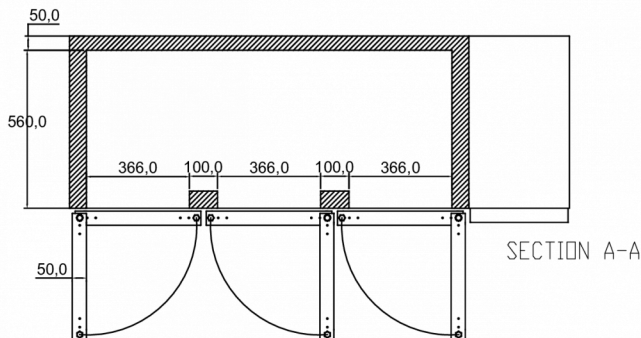

SECTION A-A

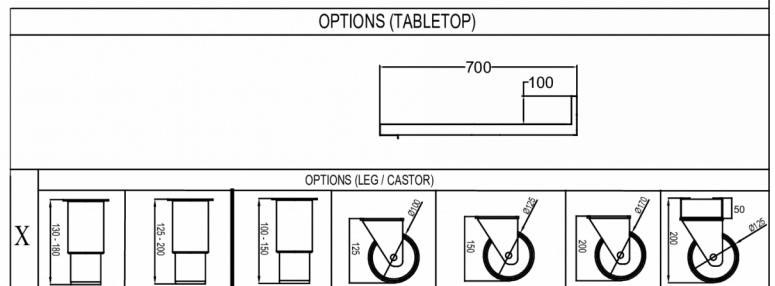

Hoshizaki Belgium
 Hoshizaki Danmark
 Hoshizaki Deutschland
 Hoshizaki France
 Hoshizaki Iberia
 Hoshizaki Italia
 Hoshizaki Middle East

info@hoshizaki.nl
info@hoshizaki.dk
vertrieb@hoshizaki.de
info@hoshizaki.fr
info@hoshizaki.es
commerciale@hoshizaki.it
sales.ex@hoshizaki-europe.com

Hoshizaki Netherlands info@hoshizaki.nl
 Hoshizaki Norge salg@hoshizaki.no
 Hoshizaki Sverige orderSE@hoshizaki.dk
 Hoshizaki UK uksales@hoshizaki.uk
 Export countries sales.ex@hoshizaki-europe.com
 Other countries sales.ex@hoshizaki-europe.com

www.hoshizaki.uk