

Premier F 2 A DL DR L E 2-Section Freezer Counter



SERIA PRODUKTU: PREMIER 270
NUMER ARTYKUŁU: 213000012100

Hoshizaki Premier F 2 A DL DR L E is a 2-section 1/1 GN freezer counter with 2 doors and a flat worktop. It has a net usable volume of 192 ltr. The shelf width is 325 mm.

- Fan assisted cooling
- Completely front vented
- Unit can be fully integrated. Due to front venting design, no air flow is required to the underneath, sides or back of unit
- Automatic defrost with re-evaporation of defrost water
- Heavy duty cabinet and compressor compartment construction
- Climate class 5 cooling system enduring up to +40°C ambient temperature
- Exterior and interior of stainless steel AISI 304
- A compact slide out refrigeration unit for maintenance and service
- Removable condenser filter for cleaning or replacement
- Compartmentalized cooling unit that is available as one unit
- Reversible doors
- Anti-tilt shelves
- Removable magnetic door gaskets with triple insulation area
- Pan-shaped inside base with rounded corners to catch fluids
- IP 2X water protection
- Matching design identity as the Premier cabinets



1 / 1 GN

AKCESORIA W KOMPLECIE

2 grey shelves per door section

OKRES GWARANCJI
6 lat na części zamienne i
robocizną

OBUDOWA
Stal nierdzewna AISI 304

WNĘTRZE
Stal nierdzewna AISI 304

Rodzaj czynnika chłodniczego: R290 / Czynnik chłodniczy: 0,055 kg /
Ekwiwalent CO2: 0,165 kg

CERTYFIKATY



Zużycie energii	Klasa efektywności energetycznej	Standardowa klasa efektywności energetycznej	Indeks efektywności energetycznej (EEI)
1 410 kWh/rok	C	ISO 22041: 2019	40,26 EEI



HOSHIZAKI

Premier F 2 A DL DR L E

SPECYFIKACJA TECHNICZNA

Zakres temperatur	Rozmiar proszku	Objętość, brutto	Objętość powierzchni netto	Klasa klimatyczna	Poziom głośności
-25/-5°C	1/1 GN	301 l	192 l	5	45 dB(A)

Zasilanie	Obciążenie przyłącza	Wydajność (w -30°C)
230V, 50Hz	425 W	376 W

SPECYFIKACJA WYSYŁKI

Szerokość (w opakowaniu)	Głębokość (w opakowaniu)	Wysokość (w opakowaniu)	Objętość (w opakowaniu)	Waga brutto	Szerokość	Głębokość	Wysokość	Wysokość z nogami (minimalna)	Wysokość łącznie z nogami (maksimum)	Waga netto
1 340 mm	730 mm	1 081 mm	1,08 m ³	112 kg	1 314 mm	700 mm	754,2 mm	884,2 mm	1 034,2 mm	100 kg

Zastrzeżenie: Every effort has been made to ensure that the information contained

in this spec sheet is accurate at the time of publishing. Hoshizaki Europe BV assumes no responsibility or liability for typographical errors or omissions or for any misinterpretation of the information within the publication and reserves the right to change without notice.

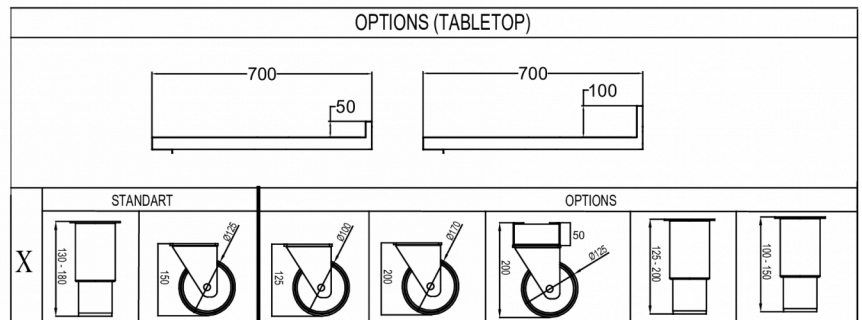
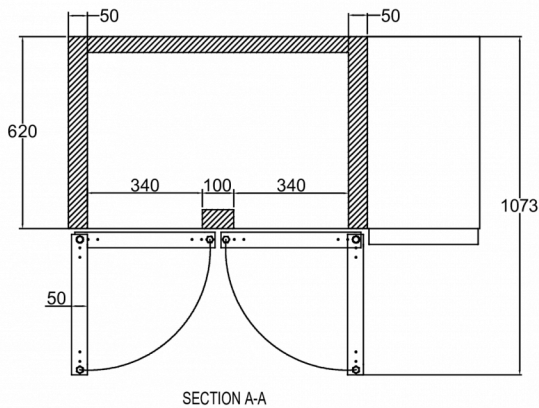
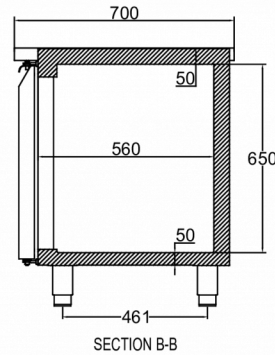
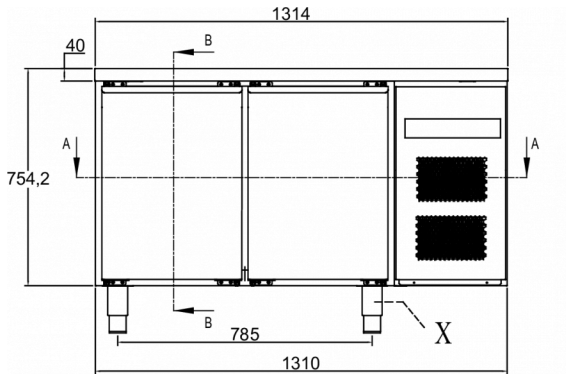

Hoshizaki Belgium
 Hoshizaki Danmark
 Hoshizaki Deutschland
 Hoshizaki France
 Hoshizaki Iberia
 Hoshizaki Italia
 Hoshizaki Middle East

info@hoshizaki.nl
info@hoshizaki.dk
vertrieb@hoshizaki.de
info@hoshizaki.fr
info@hoshizaki.es
commerciale@hoshizaki.it
sales.ex@hoshizaki-europe.com

Hoshizaki Netherlands info@hoshizaki.nl
 Hoshizaki Norge salg@hoshizaki.no
 Hoshizaki Sverige order@hoshizaki.se
 Hoshizaki UK uksales@hoshizaki.uk
 Export countries sales.ex@hoshizaki-europe.com
 Other countries sales.ex@hoshizaki-europe.com

www.hoshizaki-europe.com